

MXSELECT

RAPID CHANGE WEIGHT SYSTEMS

MX30™ DUMBBELL SYSTEM

Includes a Pair of Dumbbells, Weight Plates & Cradles

The MX30 Rapid Change Dumbbell System features our unique MX Select patented rack & pinion selection system: compact size, balanced feel and totally secure.

With the MX30 Dumbbell cradled you select the weight from 7.5-30 lbs [3.4-13.9 kg] at the turn of a dial. The selected weight level is locked into place as soon as the selector dial is pushed home.

The MX Select antimicrobial contoured grip offers surface protection against bacteria, mould & mildew, and other hazardous microbes.

One pair of MX30 Dumbbells replaces a 10-pair dumbbell set, taking up only one-tenth of the space. Safe, convenient, accurate and space-efficient, the MX30 Rapid Change Dumbbell System is a perfect addition to any home workout area.

The optional MX Dumbbell Stand elevates the Dumbbells to provide the sleek look of a professional training studio.

There is also an optional MX Select Adjustable Training Bench to further enhance your training space.

CONTOURED GRIP



MX30 - MIN Weight 7.5 lb / 3.4 kg



Weight Legend

MX30 WEIGHT LEGEND		
NO.	LBS.	NO. KGS.
1	7.5	3.4
2	10	4.5
3	12.5	5.7
4	15	6.8
5	17.5	7.9
6	20	9.1
7	22.5	10.2
8	25	11.3
9	27.5	12.5
10	30	13.9

CAUTION
DO NOT DROP!
DUMBBELL WEIGHTS TO BE HANDLED WITH CARE TO PREVENT INJURY.
SELECTOR DIAL MUST BE DEPRESSURED TO LOCK WEIGHT IN PLACE BEFORE USE.
www.MXSelect.com

MX30 - MAX Weight 30 lb / 13.9 kg



* Antimicrobial properties built-in to the contoured dumbbell grip offer surface protection against bacteria, mould & mildew and other hazardous microbes.



CONTOURED GRIP

SPECIFICATIONS & DIMENSIONS

DUMBBELL SYSTEM WEIGHT RANGE	+ 7.5-30 lbs in 2.5 lb increments	+ 3.4-13.9 kg in 1.12 kg increments
DUMBBELL LENGTH - MINIMUM WEIGHT	+ 9.58" - MIN 7.5 lbs	+ 24.3cm - MIN 3.4 kg
DUMBBELL LENGTH - MAXIMUM WEIGHT	+ 15.94" - MAX 30 lbs	+ 40.5cm - MAX 13.9 kg
HANDLE DIMENSIONS	+ Grip Length 5.31" 13.5 cm	+ Grip Diameter 1.29" 3.27 cm
FOOTPRINT - PAIR OF DUMBBELLS	+ 15.7" L x 12.9" W x 6.6" H	+ 40.1 cm L x 32.8 cm W x 16.9 cm H
TOTAL WEIGHT - PAIR OF DUMBBELL & CRADLE	+ 66 lbs	+ 29.9 kg

MATERIALS

DUMBBELL BODY	+ Steel
DUMBBELL GRIP	+ Antimicrobial Contoured Grips
WEIGHT PLATES	+ Steel Coated in Polyanide Nylon
HANDSET MECHANISM	+ Steel and ABS
WEIGHT RACK & CRADLE	+ Powder Coated Steel

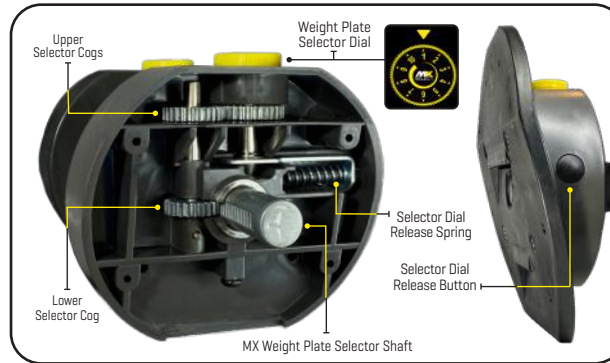

MX30 DUMBBELLS	Box per Unit	Length mm	Width mm	Height mm	Nett Kg	Gross Kg	Cubic Meters	Length Inches	Width Inches	Height Inches	Nett Lb	Gross Lb	Cubic Foot
	BOX 1	490	240	250	36.00	38.00	0.06	19.29	9.44	9.84	79	83	1.59
	BOX 2												



CONTOURED GRIP

*Antimicrobial Contoured Grip

MX Patented Handset Cradle

Weight Legend

MX Handset Cradle Feet

Weight Selector Dial

Weight Selector Release Button

Ten x 1.25 lb / 0.57 kg Weight Plates per side

MX30™ WEIGHT LEGEND				
NO.	LBS.	CAUTION	NO.	KGS.
1	7.5	DO NOT DROP! DAMAGE MAY RESULT TO HANDSET COMPONENTS AND WEAR WARRANTY. SELECTOR DIAL MUST BE DEPRESSED TO LOCK WEIGHTS IN PLACE BEFORE USING. www.MXSelect.com	1	3.4
2	10		2	4.5
3	12.5		3	5.7
4	15		4	6.8
5	17.5		5	7.9
6	20		6	9.1
7	22.5		7	10.2
8	25		8	11.3
9	27.5		9	12.5
10	30		10	13.9

10 YEAR WARRANTY
PLEASE READ & FOLLOW
INSTRUCTIONS CAREFULLY
BEFORE USING PRODUCT
© 2018 MX SELECT
SAFETY FIRST ALWAYS
WEIGHTS ARE APPROXIMATE

* Antimicrobial properties built-in to the contoured dumbbell grip offer surface protection against bacteria, mould & mildew and other hazardous microbes.

