

# **MX DUMBBELL STAND**

Made for MX30, MX55 & MX85  
Dumbbell Weight Cradles (without feet)

## **ASSEMBLY & SYSTEM ADJUSTMENTS**

### **MXSTAND**



+



=



## **MX SELECT - USER SAFETY PRECAUTIONS**

To avoid possible injury, all users should read and understand these instructions before using any MX Select product.

1. Consult a medical doctor or healthcare professional to be cleared by them for exercise and to determine the exercises appropriate for you, before undertaking exercise with MX Select Systems.
2. If you experience any pain or dizziness, stop exercise immediately and consult a medical doctor.
3. Perform any exercise with the correct technique - consult a personal trainer or healthcare professional for guidance if unsure of technique or your personal exercise parameters.
4. MX SELECT Systems are designed for home use only and are not suitable or warranted for commercial use.
5. Understand how to select the desired weight with the MX SELECT System, see page 2 following.
6. Never touch the weight selector release button or move the selector dial while the MX Select product is out of the cradle, doing so may release weight plates from the handset and cause catastrophic injury.
7. Never use MX Select Systems if they are not functioning properly.
8. Never drop, throw or strike together any MX Select System, this will void warranty and could cause permanent damage.
9. Take personal responsibility to ensure your safety and the safety of those around you while using and storing MX SELECT Systems.



### HOW TO SELECT DESIRED TRAINING WEIGHT

Only adjust the Weight Selector Dial while the Dumbbell is in the Weight Cradle



Adjust both ends of the Dumbbell to your desired training weight.

### ASSEMBLY INSTRUCTION - MX STAND



**STEP ONE** Place the MX Stand box on a flat firm surface with the Up Arrow pointing up. Open the top of the box and remove the Stand Uprights.



**STEP TWO** The owners guide and hardware kit is visible on the bottom of the box below the Stand Rear Support. Remove the hardware kit from the plastic sleeve and put the Bolts and Allen Keys aside. Remove the Stand Rear Support.



### STEP THREE - ASSEMBLE THE STAND

Lay the Stand Uprights on the floor (careful not to damage the floor or stand coating) and place the Stand Rear Support in position to line up the bolt pattern on both parts.

Ensure the MX SELECT decal faces outwards on both Stand Uprights and that the Warning decal on the Stand Rear Support will face up when assembled. Attach the Stand Uprights to the Stand Rear Support using 4 Stand bolts with washers – DO NOT fully tighten at this time.

Place Stand assembly on the floor as shown, checking to make sure the Stand assembly sits evenly on the floor.

**FULLY TIGHTEN STAND BOLTS.**

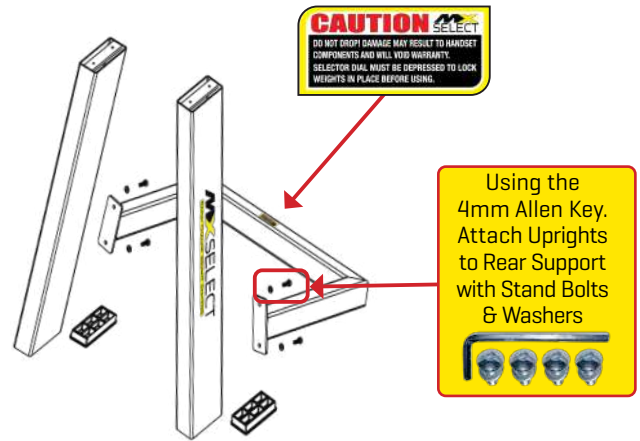

### STEP FOUR

If the MX Dumbbell Cradle does not have the Cradle Feet fitted, go to Step 5; otherwise, follow the “How to Select desired training weight” instructions above, and set the dial to 10, remove the MX Dumbbell Handset from the Cradle and put aside. Setting 10 is the HEAVIEST, so take care when lifting and placing the dumbbell. Turn the Cradle over and, using a 4mm Allen Key remove the Cradle Feet bolts and Cradle Feet.

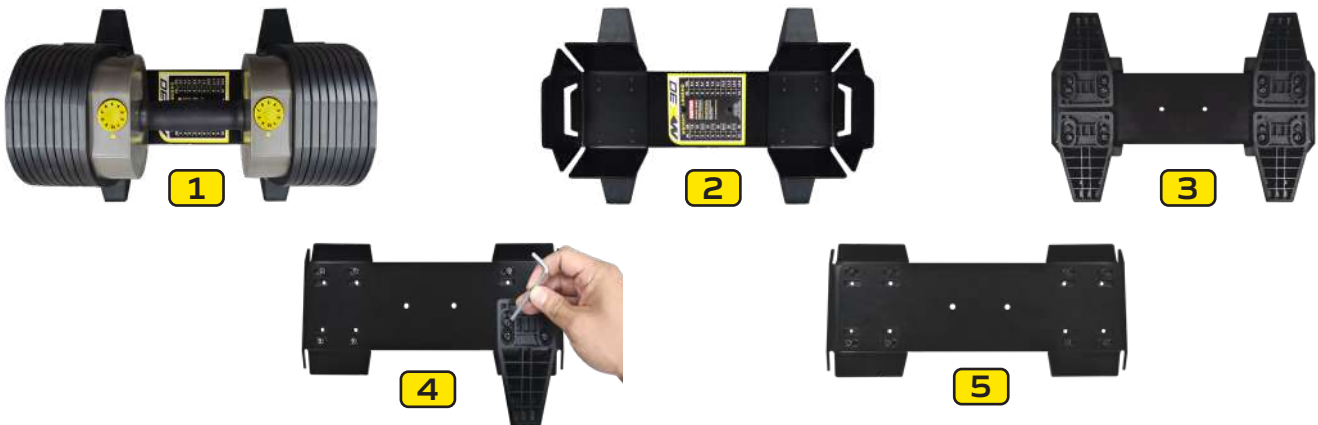

### STEP FIVE - ATTACHING THE CRADLES TO THE STAND

Loosely attach one Cradle on top of a Stand Upright using 2 of the Cradle Countersunk Bolts making sure the Weight Legend can be read from the front. Repeat with the other Cradle. Tighten all bolts making sure the Cradles stay parallel.

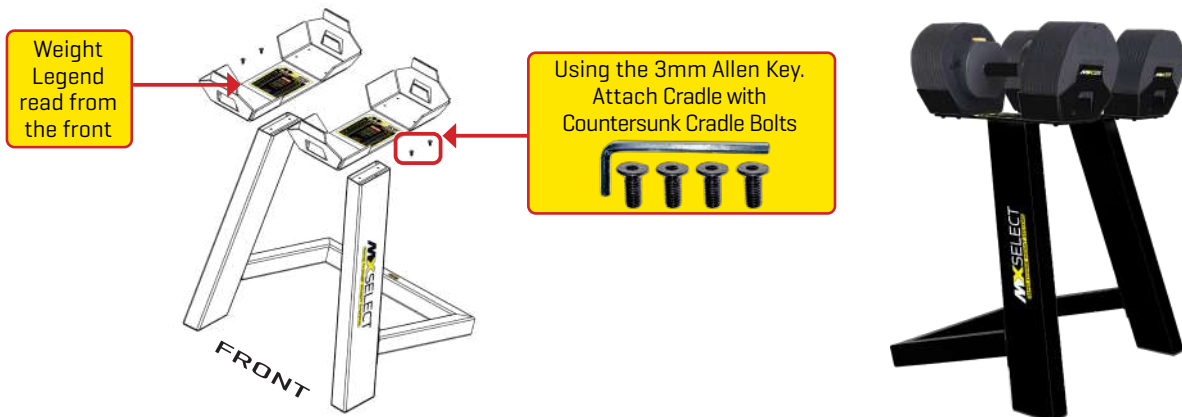

### MX DUMBBELL ADJUSTMENT GUIDE

#### FOR SMOOTH & ACCURATE WEIGHT PLATE SELECTION

##### STEPS TO RESOLVE THE FOLLOWING

- + Selector dial will not push down and lock into place.
- + Selector dial feels tight or will not turn easily.
- + Extra weight plate sticks when the MX Dumbbell Handset is removed from Cradle.
- + Weight plates are too widely spaced or too closely spaced.

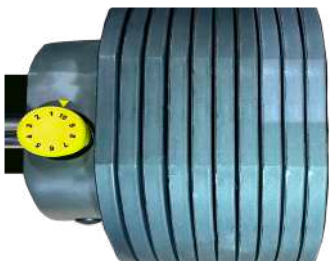

**CRADLE SPACING TOO WIDE**  
Weight plates move freely when in Cradle

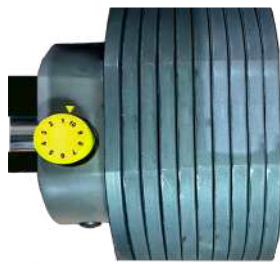

**CORRECT SPACING**  
Weight plates have a thin gap but don't move freely

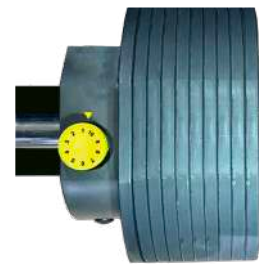

**CRADLE SPACING TOO CLOSE**  
Cant remove weights and selector dial won't turn

##### STEP ONE

With the MX Dumbbell Handset still in Cradle, locate adjustments bolts in the slots underneath Cradle.



Adjustment bolts in slotted holes

##### ADJUSTMENT SLOTS



##### STEP TWO

Using a M4 Allen Key loosen the 4 Adjustment Bolts at one end of the MX Dumbbell Cradle just enough to allow you to move the Cradle as required.



M4 ALLEN KEY



##### IF CRADLE SPACING TOO WIDE

Push the floating cradle end inwards, closing the gap between the plates. Tighten bolts and test on all dial settings. If not correct, repeat adjustment steps.

##### IF CRADLE SPACING TOO TIGHT

Move apart floating cradle end outwards, opening a slight gap between the plates. Tighten bolts and test on all dial settings. If not correct, repeat adjustment steps.